

VISTE DA SOTTO - LATO ATTACCHI
VIEW FROM BELOW - CONNECTIONS SIDE

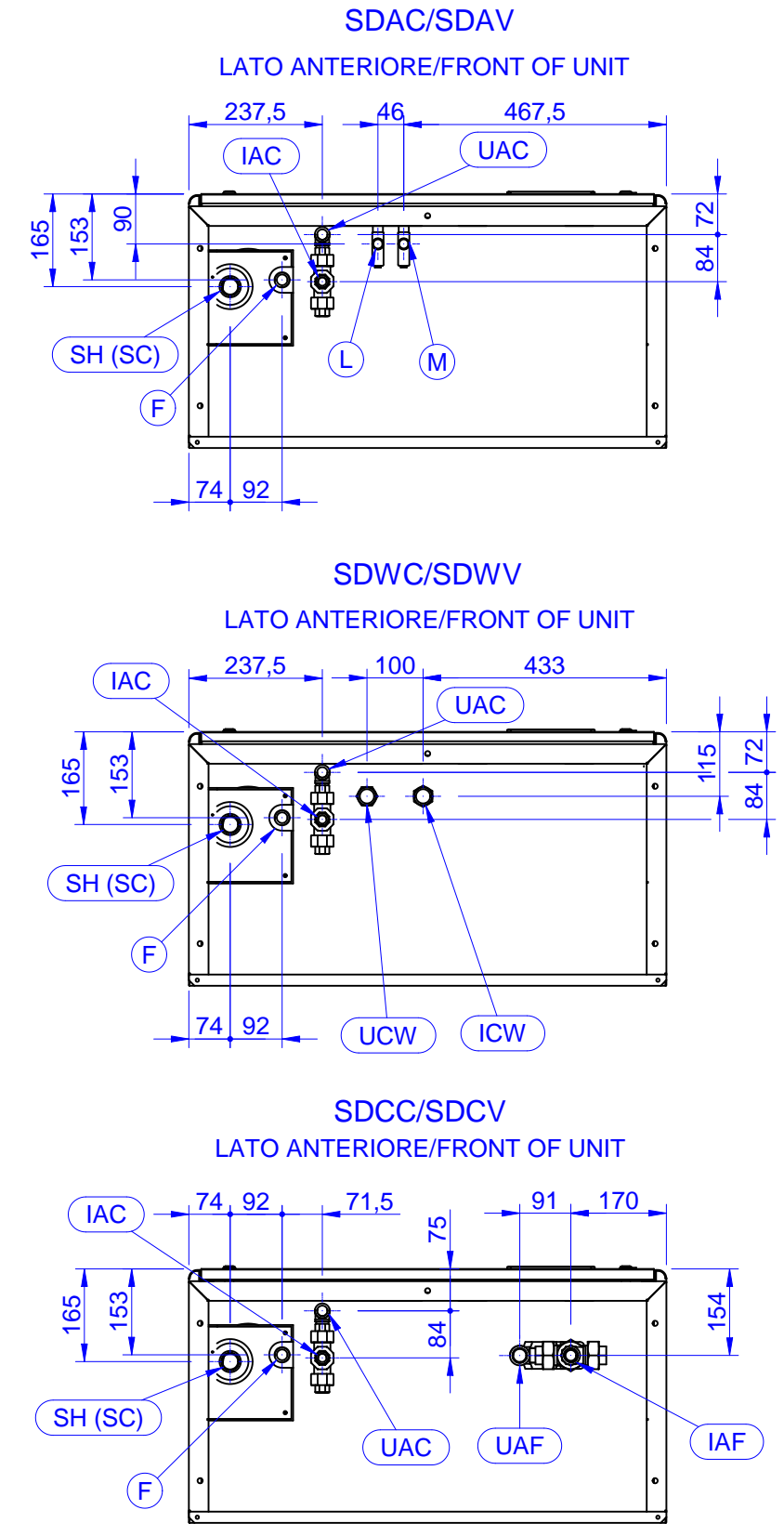

0	PRIMA EMISSIONE FIRST RELEASE	-	-	-	-
Rev.	Descrizione-Description	Dis.-Draftsman	Data-Date	Visto-Checked	N°com.
		Denominazione-Denomination		Serie-Series	
		SCHEMA DI INSTALLAZIONE OVERALL DIMENSIONS		SDA. - SDW. / SDC. Modello-Model 0331-0351 / 0250.0400	
Scala-Scale		Foglio-Sheet N.	Dis.-Draftsman	Data-Date	Disegno-Drawing
-		1/2	S. Cazzolla	23/04/2010	06DI0044
					Rev. 0

	Italiano	Inglese	Tedesco	Francese	Spagnolo	Attacchi Connections Wasseranschlüsse Conexiones Conexiones
F	ALIMENTAZIONE UMIDIFICATORE	HUMIDIFIER FEEL	WASSERVERSORGUNG	ALIMENTACION DEL HUMECTATOR	ALIMENTACION HUMIDIFICADOR	Ø 6
IAC	INGRESSO ACQUA CALDA	HOT WATER INLET	WARMWASSEREINGANG	ENTREE EAU CHAUDE	ENTRADA DE AGUA CALIENTE	UNI ISO 228/1-G1/2
IAF	INGRESSO ACQUA FREDDA	CHILL WATER INLET	KAELTWASSEREINTRITT	ENTREE EAU FROIDE	ENTRADA DE AGUA FRIA	UNI ISO 228/1-G3/4
ICW	INGRESSO ACQUA	WATER INLET	WASSEREINGANG	ENTREE EAU	ENTRADA DE AGUA	UNI ISO 228/1-G1 A
L	LINEA LIQUIDO	LIQUID LINE		LIQUIDE DE LIGNE	Línea de líquido	ODS 16
M	LINEA MANDATA	DISCHARGE LINE		LIGNE D'ALIMENTATION	SUMINISTRO DE LÍNEA	ODS 16
PRA	POST-RISC ACQUA CALDA	REHEAT WATER COIL	HEISSWASSERNACHHEIZUNGSREGISTER	POST CHAUFFAGE EAU CHAUDE	POST-CALENDAMENTO POR AGUA CALIENTE	/
SC	SCARICO CONDENSA	CONDENSATE DRAIN	KONDENSATWASSERENTLEERUNG	CONDENSATO DREN	PURGADOR DE CONDENSADOS	Ø 32
SH	SCARICO UMIDIFICATORE	HUMIDIFIER DRAIN	BEFEUCHTERENTFUHLUNG	DREN DE HUMECTATOR	HUMIDIFICADOR DRENAJE	Ø 32
UAC	USCITA ACQUA CALDA	HOT WATER OUTLET	WARMWASSEREAUSGANG	SORTIE EAU CHAUDE	SALIDA DE AGUA CALIENTE	UNI ISO 228/1-G1/2
UAF	USCITA ACQUA FREDDA	CHILL WATER OUTLET	KALTWASSERANSCHLUSS	SORTIE EAU FROIDE	SALIDA DE AGUA FRIA	UNI ISO 228/1-G3/4
UCW	USCITA ACQUA	WATER OUTLET	WASSEREAUSGANG	SORTIE EAU	SALIDA DE AGUA	UNI ISO 228/1-G1 A

	PESO (Versione completa) WEIGHT (Full Version) GEWICHT (Vollversion) POIDS (version complète) PESO (Versión Completa)
SDAC 0331-0351	160 kg
SDAV 0331-0351	160 kg
SDWC 0331-0351	165 kg
SDWV 0331-0351	165 kg
SDCC 0250-0300	125 kg
SDCC 0400	150 kg
SDCV 0250-0300	135 kg
SDCV 0400	145 kg

0	PRIMA EMISSIONE FIRST RELEASE	-	-	-	-
Rev.	Descrizione-Description	Dis.-Draftsman	Data-Date	Visto-Checked	N°com.
		Denominazione-Denomination SCHEMA DI INSTALLAZIONE OVERALL DIMENSIONS		Serie-Series SDA. - SDW. / SDC. Modello-Model 0331-0351 / 0250.0400	
	Scala-Scale -	Foglio-Sheet N. 2/2	Dis.-Draftsman S. Cazzola	Data-Date 23/04/2010	Disegno-Drawing 06D10044
					Rev. 0